

# NUMERICAL SIMULATION OF MOLD FILLING AND THERMAL BEHAVIOR IN THE MANUFACTURING OF AN AERONAUTICAL COMPOSITE PART

M. A. Oceau<sup>1,3</sup>, J. Feuvrier<sup>2</sup>, S. Soukane<sup>2</sup>, F. Cloutier<sup>2</sup> and F. Trochu<sup>2</sup>

<sup>1</sup> *Aerospace Manufacturing Technology Centre (AMTC), Institute for Aerospace Research, National Research Council of Canada, P.O. Box 40, Station Côte-des-Neiges, Montreal, H3S 2S4*

<sup>2</sup> *Department of Mechanical Engineering and Chair on Composites of High Performance, Centre de recherche en plasturgie et composites (CREPEC), École Polytechnique de Montréal, P.O. Box 6079, Station "Centre-Ville", Montreal (Quebec), Canada, H3C 3A7*

<sup>3</sup> *Corresponding author's Email: marc-andre.oceau@cnrc-nrc.gc.ca*

**SUMMARY:** Resin Transfer Molding (RTM) has become a cost efficient manufacturing process for small to medium size composite parts in aeronautic applications. The filling of the mold remains a critical step to achieve proper part quality and process repeatability. The injection scenario depends on several parameters such as the location of the inlet gates and vents, edge effects, preferential flow channels, preform permeability, mold and resin temperatures, resin viscosity and reaction kinetics. Most of these injection parameters cannot always be determined precisely and some process conditions are likely to vary from one injection to another such as edge effects for example. To achieve a repeatable part quality, designers have to ensure that major issues such as air entrapment or fiber washout are prevented during filling of the mold cavity. In the present work, the main goal is to define a robust injection processing window based on process numerical simulation. This work requires experimental characterization of preform permeability and subsequent RTM flow simulations. The simulation results will demonstrate the critical parameters to control in order to achieve good part quality.

**KEYWORDS:** Resin Transfer Molding (RTM), numerical simulation, injection, processing

## INTRODUCTION

Resin transfer molding (RTM) is a process well suited to meet the growing demand in the aerospace industry to produce high performance parts at a reduced cost [1-3]. This paper presents the study performed to define a processing window for RTM manufacturing of an aeronautic component based on material characterization and injection simulation. In the study, fibers and resin are characterized experimentally to measure the parameters, permeability and viscosity,

needed for simulating the injection process. However depending on the part geometry and material consistency, these parameters can vary significantly thus modifying the injection pattern and possibly creating defects in the part during the injection. Therefore, critical area and parameters are identified and injection simulations are performed using different parameter values in order to scale the effect of those variations. Then a robust RTM manufacturing process is defined with proper injection and vent gates locations as well as indication for critical areas where greater care is needed during the part fabrication.

## PROJECT DESCRIPTION

This study on the definition of a robust manufacturing process for RTM is part of a collaborative project between McGill University, École Polytechnique de Montréal, the National Research Council of Canada (Aerospace Manufacturing Technology Centre, Institute for Aerospace Research), Bell Helicopter Textron Canada, and Delastek Inc. The general goal is to facilitate the design of structures made from composite materials and reduce manufacturing costs at the same time. By taking an integrated approach to RTM, development time for making parts can be reduced and properties improved [3]. Injection simulations play an important role in defining a robust manufacturing process and thus have a direct incidence on the development time, mold cost and part performance.

The component selected is an aerodynamic leading edge slat mounted onto the horizontal stabilizer of a helicopter tailboom (see Fig. 1). The slat assembly is roughly 1 m long with a chord length of 75 mm with four integrated brackets (see Fig. 2) and is connected to the horizontal stabilizer with eight fasteners. The slat airfoil and four brackets are to be molded as a single piece to reduce part count and assembly steps. The part molded for development purposes consists of half the original slat length with the original airfoil cross section and two full scale brackets. The two brackets have different geometries to evaluate the performance and manufacturability of an open and a closed contours bracket (see Fig. 3). The molded prototype has some extended edges to accommodate for extra material during the fiber wrap up and also for the proper demolding angle as shown in Fig. 3 by the red section trimmed after cure.

RTM is a closed mold process which produce high quality part with controlled surfaces on all sides ideal for assembly and aerodynamic application. Also, it allows the integration of complex features and the molding of hollow structures. The selected slat component in this study demonstrates these characteristics. RTM consists of loading a dry fiber preform in a closed mold followed by injecting a low viscosity resin through the fiber preform. The flow of the resin through the preform is governed by Darcy's law:

$$v = -\frac{1}{\mu}(K \bullet \nabla P) \quad (1)$$

where  $v$  is the volume flow rate per unit area,  $K$  is the permeability tensor,  $\mu$  is the resin viscosity and  $\nabla P$  is the pressure gradient. The pressure gradient  $\nabla P$  is defined between the injection pressure and the pressure at the flow front.

The boundary conditions affecting the flow pattern are edge effects between the fiber preform and the mold as well as distribution lines for resin injection and vent. Material variability can

occur in both the viscosity and permeability. The resin viscosity varies with temperature and kinetics. However in this aeronautic application, the injection is done isothermally and the resin system used is low reacting, therefore the resin viscosity does not vary during the injection. The permeability of the fiber preform depends on the fiber architecture, fiber orientation, ply stack up, fiber volume ratio and fiber shearing angle when deformed in a 3D shape.

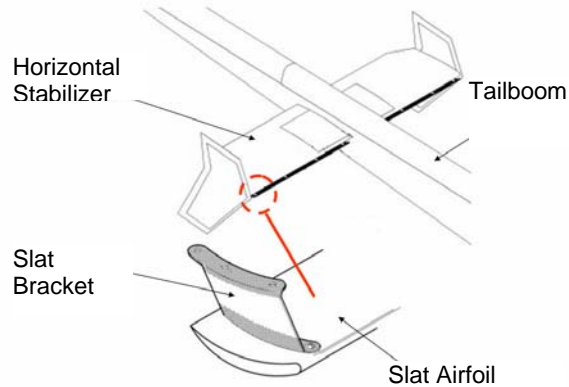

Fig. 1 Aerodynamic slat on horizontal stabilizer.

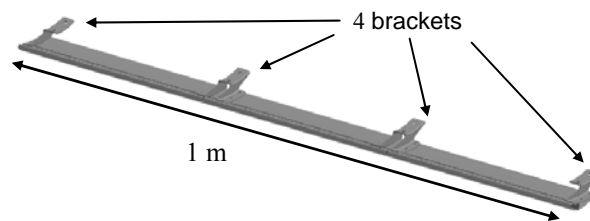

Fig. 2 Original leading edge slat with attachment brackets.

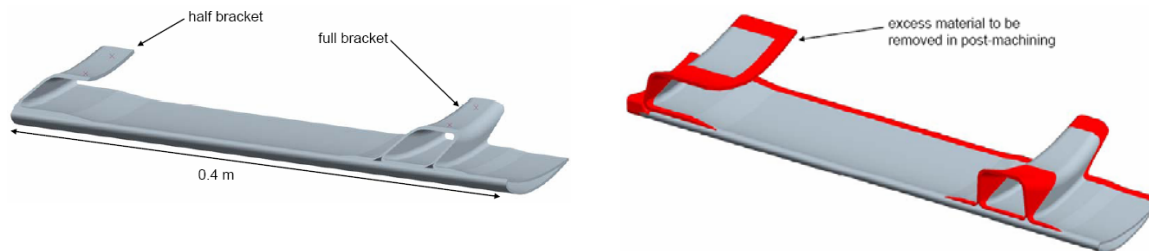

Fig. 3 Slat section used in the study.

## Material Characterization

The viscosity has been measured isothermally using a rheometer at the injection temperature of 80°C. The measured viscosity is constant at 0.39 Pa·s. The permeability depends on the fiber architecture and fiber orientation. In this study it is a 5 harness satin. The warp and weft orientation and the fiber orientation in the part are defined accordingly to Fig. 4 where the  $x$  direction corresponds to 0°.

The prototype slat has two ply stack-ups defined, one for the brackets and one for the airfoil section. The 5 harness satin fabric used for the slat fabrication has been characterized experimentally to measure the permeabilities in three fiber orientation (0°, 45° and 90°). These

values are used to establish the permeability tensors in the airfoil and the bracket ply stack-ups. The airfoil stack-up ( $45^\circ/45^\circ/45^\circ/45^\circ$ ) uses the permeability tensor calculated from the measured value for the  $45^\circ$  ( $K_1 = 3.1 \cdot 10^{-10} \text{ m}^2$ ,  $K_2 = 4.2 \cdot 10^{-10} \text{ m}^2$ ,  $\beta = 95^\circ$ ). The permeability tensor for bracket stack-up ( $0^\circ/45^\circ/45^\circ/45^\circ/0^\circ$ ) is calculated using a method developed by Demaria et al. [3] ( $K_1 = 4.1 \cdot 10^{-10} \text{ m}^2$ ,  $K_2 = 3.2 \cdot 10^{-10} \text{ m}^2$ ,  $\beta = 94^\circ$ ).

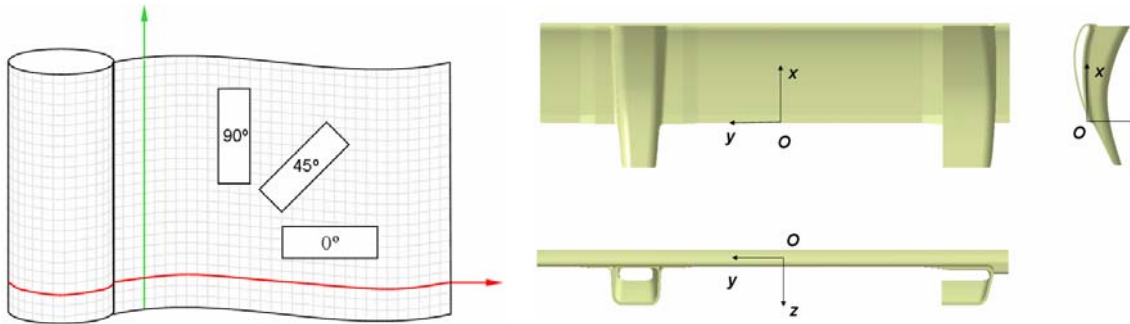

Fig. 4 Fiber orientation along the warp and weft and in the part.

In the case of the airfoil stack-up, the fibers are wrapped around a mandrel and the fiber angles are not deformed during the performing operation. However for the bracket stack-ups, the fibers are preformed on a 3D insert and the fiber angle is subjected to shearing. The fiber shearing angle can be predicted using QUIK-FORM [6]. Fig. 5 shows the evolution of the fiber shearing angle in the brackets. Other than changing the fiber angle, the shearing of the fibers also increases the fiber volume ratio which incidentally reduces the permeability of the ply stack-up. The permeability in the brackets where the fibers are subjected to shearing is adjusted for an increase in fiber volume ratio with the Kozeny-Carman's law.

Another source of permeability variation is the junction between the bracket and the airfoil section. This junction creates a preferential channel where the resin can flow faster (see Fig. 6). This channel can be filled with unidirectional fibers but this region remains a source of permeability variability. For the definition of a robust processing window, simulations are performed with a permeability range between  $10^{-9}$  and  $10^{-11} \text{ m}^2$  representing both cases where this junction channel has either a higher or a lower permeability value than the fiber preform. All these considerations lead to a model with the different zones of permeability of Fig. 7.

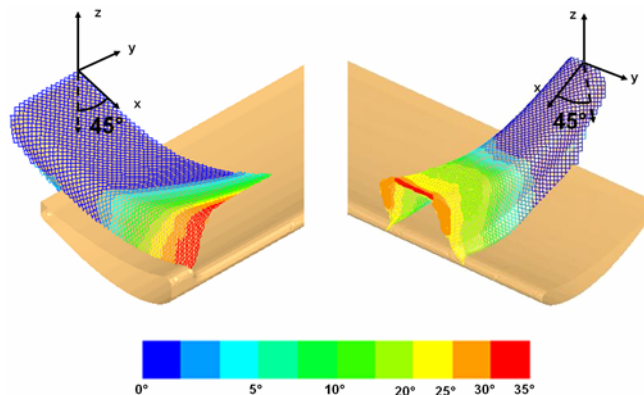

Fig. 5 Fiber shearing angle prediction using QUIK-FORM [5].

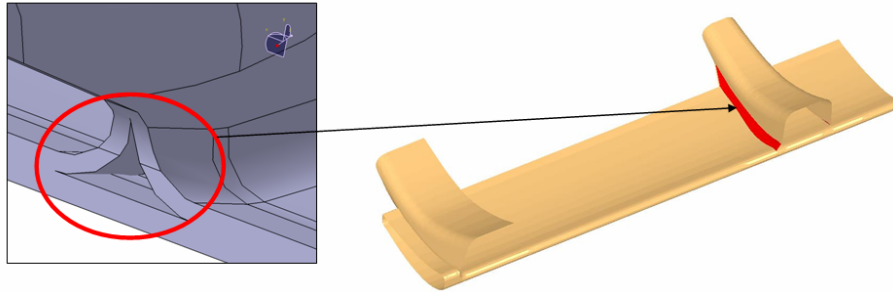

Fig. 6 Junction region between the bracket and the airfoil.

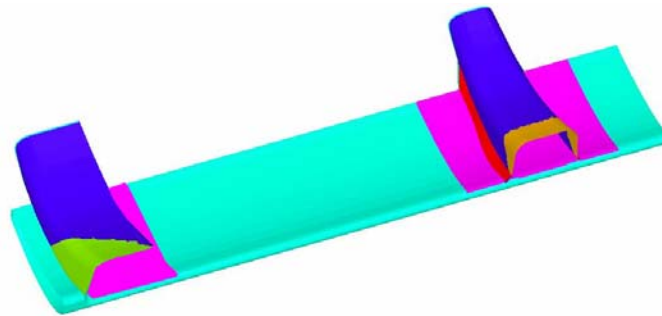







Fig. 7 Model with different permeability zones for injection simulation.

### Preform and Edge Effects

The preform and mold also has an effect on the resin flow. Preferential channels can be present in the mold either intentionally or unintentionally. The first one is used as a distribution channel for the resin to form an injection line with one injection point. The second one is due to the difficulty of perfectly match the fiber preform to a mold edge. In both cases, the distribution channel or the edge effect allow the resin to flow faster than through the porous fiber preform. In term of injection simulation, these channels have a permeability assigned to them in order to demonstrate the accelerated resin flow.

Table 1 Ply stack-ups definitions

Zone	Couleur	Épaisseur	Identification
1		1,51 mm	Séquence 45°/45°/45°/45°
2		2,27 mm	Séquence 0°/45°/45°/45°/45°/0°
3		3,78 mm	Séquences 45°/45°/45°/45° et 0°/45°/45°/45°/45°/0°
4		2,27 mm	Séquence 0°/45°/45°/45°/45°/0° cisailé à 25°
5		2,27 mm	Zone de jonction

Since the edge effects are due to the difficulty to precisely cut and place a dry preform in the mold, the size of this edge effect can be estimated from none to roughly the size of one or two

fiber tows in the fabric. In this study, the gap between the mold and fiber preform is evaluated to be up to a maximum of 3 mm. This allows using the relationship of Hammami et al. [1] to calculate an equivalent permeability for the edge effect where  $d$  is the gap:

$$K_{bord} = \frac{d^2}{12} \quad (2)$$

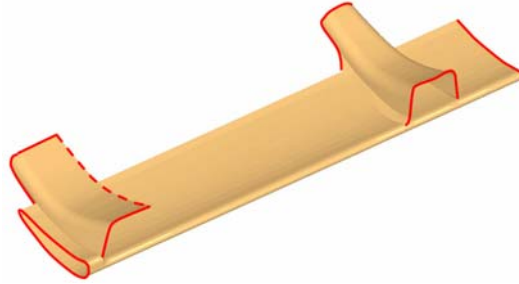

Fig. 8 Location of possible edge effects.

For the prototype slat, the dotted line in Fig. 8 is the most critical edge effect that can create problems such as a dry spot or high porosity zone in the final part. Therefore, the injection simulations focus on different scenarios with no edge effect along the dotted line and an important one (3 mm gap) between the fiber preform and the mold. The equivalent permeability given by Eqn. 2 is then  $7.5e-7 \text{ m}^2$ .

Distribution channels are placed in the mold to create a line injection. Their size is greater than 3 mm, so Eqn. 2 cannot be used. A higher permeability is necessary to model distribution channels. However, to prevent malfunction of the simulation code, the difference in permeability is limited to 4 in order of magnitude, thus leaving the distribution channel permeability to  $10^{-7} \text{ m}^2$ .

### Injection Strategy

The injection strategy selected for the prototype slat is two injection ports located on top of the brackets with a distribution channel along the trailing edge of the slat as shown in Fig. 9. In order to study the consequence of the edge effect and the preferential channel at the junction between the bracket and the airfoil as described in the section above, four different configurations are simulated using PAM-RTM [8] to study the combination of the extreme value of those two factors. The different combinations for those factors are listed in Table 2.

Table 2 Permeability of possible configuration for injection simulation

Configuration	Permeability at junction zone ( $\text{m}^2$ )	Edge effect on bracket dotted line in Fig. 8
1	$10^{-9} \text{ m}^2$	$7.5 \times 10^{-7} \text{ m}^2$
2	$10^{-9} \text{ m}^2$	no edge effect
3	$10^{-11} \text{ m}^2$	$7.5 \times 10^{-7} \text{ m}^2$
4	$10^{-11} \text{ m}^2$	no edge effect

For sake of brevity, simulation results for only two of the four combinations are shown in Fig. 10 and Fig. 11 for Configurations 1 and 3. An important edge effect is caused by the assumed 3 mm

gap between the preform and the mold. This means a high possibility of having a dry spot or high void content in the open contour half bracket. Combinations 1 and 2 where the permeability of the junction between the closed contour bracket and the airfoil is higher than of the fiber stack itself. This leads to a faster flow in the closed contour bracket than for the rest of the part. As seen in Fig. 10, the flow front is not even across the part and the resin reaches the leading of the airfoil three times faster in front of the closed contour bracket than in the airfoil section or even for the open contour bracket.

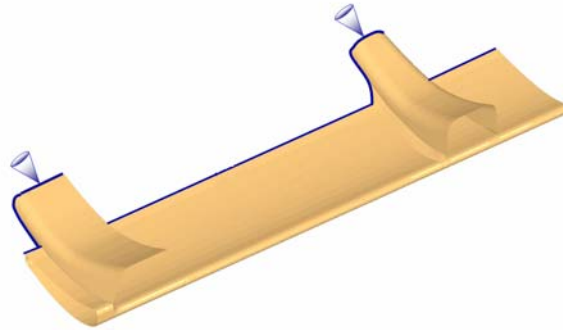

Fig. 9 Injection strategy with two injection ports and a distribution channel.

The red arrows in the injection simulation results show where the flow front end. When there is more than one arrow per result, this means that more than one vent is required in the mold since the flow front does not end in one definite area. However, in all cases, the vent locations are located along the leading edge of the airfoil and on the final edge of the brackets. Therefore, the vent gate is placed in the mold in a similar manner as for the injection port and a vent line is incorporated in the mold along the leading edge of the airfoil and on the final edge of the brackets. However, if the flow front does not reach the vent line uniformly, the resin will fill the vent line before the part is completely injected.

### Thermal Simulations

To be sure that the resin polymerization is complete in a cycle time, thermal simulations have to be realized. They have been done on a vertical section of the mold at the level of the full bracket. The simulations are divided into three stages: preheating (one hour), injection, cure (two hours). For each simulation, the finite element software solves the temperature problem and for the injection and the cure, calculates the resin polymerization.

Four electric cartridges in each mold assure the heating. A convection condition is set on the boundary of the mold. The temperature in the mold at the end of the preheating is shown on the following figure. Of course, due to heat loss, the temperature is not the same in the entire mold. The temperature in the bracket is ten degrees lower than in the cartridges. A sensor saved the resin polymerization in the middle of the bracket in function of the time. This data is shown in Fig. 16. The purple curve gives the cure degree for a heating temperature of 450°K. In this configuration the sensor is at 441°K. The conclusion on the thermal analysis is that two hours of cure at 450°K are not enough to reach a sufficient cure degree. To get a cure degree higher than 0,9 after two hours, a temperature of 470°K is needed. At 450°K two hours and a half of cure would be enough to attain this cure degree. Finally, insulation of the mold is another possible solution to increase the resin cure.

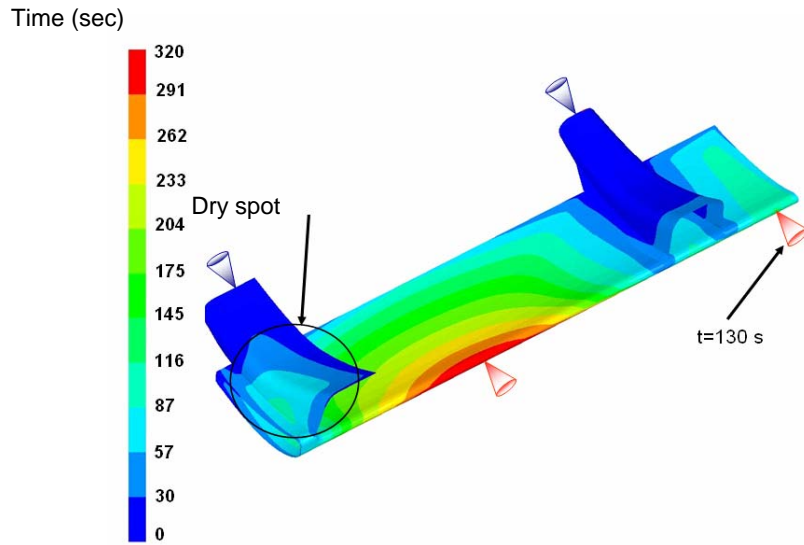

Fig. 10 Injection simulation result for Configuration 1.

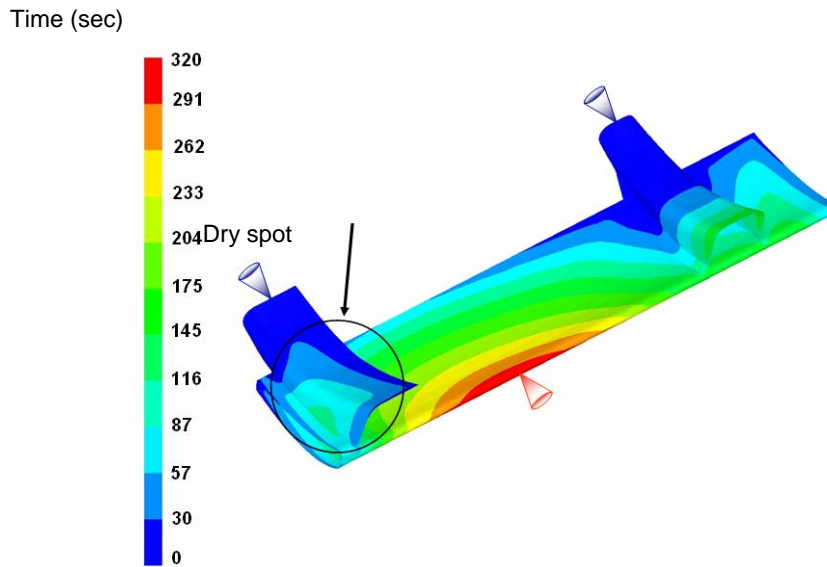

Fig. 11 Injection simulation result for Configuration 3.

## CONCLUSION

Injection simulations were used in conjunction with material characterization to study the variability of material parameters as well as the interaction between the mold and the fiber preform on part quality. The part being considered for this project was the leading edge slat on the horizontal stabilizer of a helicopter. The material parameters for the injection simulation, resin viscosity and fiber permeability, were characterized experimentally. Also, the fiber permeability was adjusted locally after simulating the shearing of the fiber angle in the slat brackets. Critical areas where the local permeability can change such as in edge effect and preferential channel in part junction that can cause problem during the injection were identified and a range of extreme permeabilities were assigned to those areas for simulations. Four



different configurations were simulated to study the combinations of the two permeability values for the preferential channel in the junction between the closed contour bracket and the airfoil and the two permeability values for the edge effect on the open contour bracket.

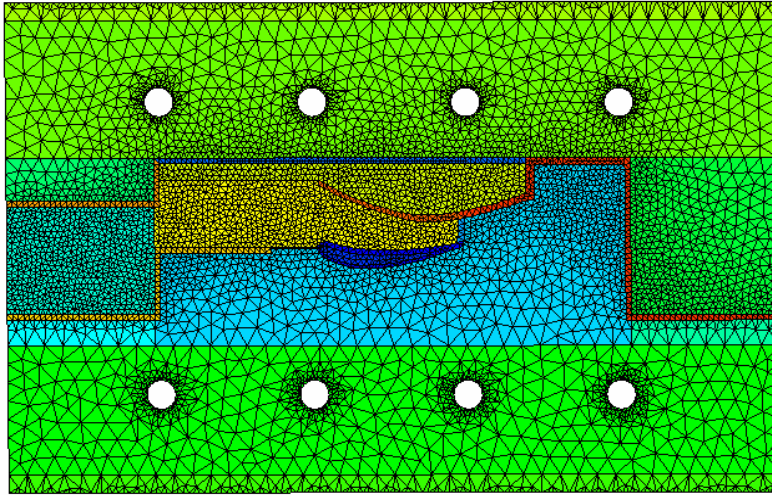

Fig. 12 Mesh of the mold.

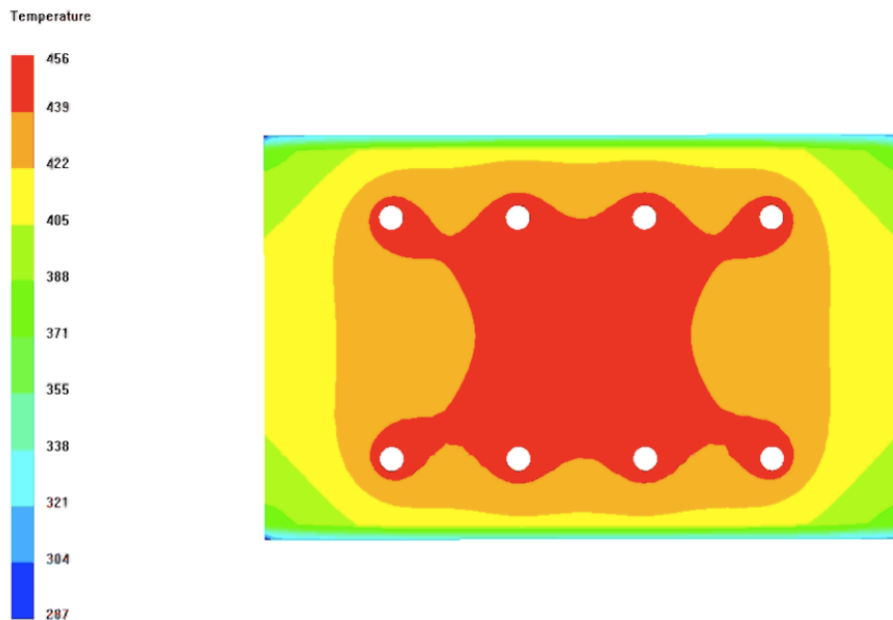

Fig. 13 Temperature in the mold at the beginning of resin injection.

Using injection simulation, it was demonstrated that the edge effect on the open contour bracket can lead to dry spot or high void content in the part since the resin can flow faster on the edge of the bracket thus leaving a section of it dry. It was also demonstrated that when the permeability of the junction between the closed contour bracket and the airfoil is higher than the fiber preform permeability, the flow of the resin reaches the vent line before the rest of the part is fully injected. Therefore to ensure good part quality, it is important to prevent the edge effect of the open contour bracket and to make sure that the junction between the closed contour bracket and the airfoil is filled with unidirectional fibers in order to increase its permeability higher than the part fiber preform.

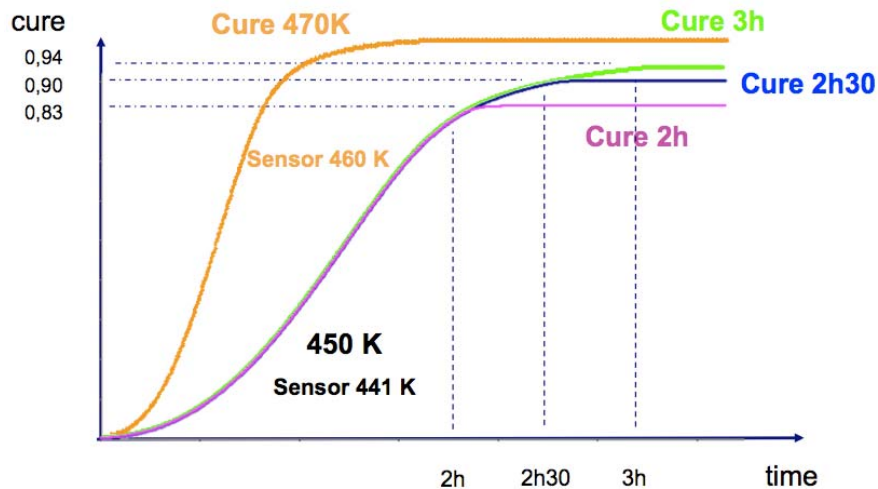

Fig. 14 Cure rate in the bracket in function of time for different heating temperatures

### ACKNOWLEDGEMENTS

The authors would like to thank all members of the CRIAQ Project 1.15 team. Support for this project is also provided by the Consortium for Research and Innovation in Aerospace in Quebec (CRIAQ), the “Centre de recherche en plasturgie et composites” (CREPEC) and the Natural Sciences and Engineering Research Council of Canada (NSERC).

### REFERENCES

1. M. Louderback et al., “Affordable Unitized Composite Structures for Rotorcraft”, presented at the *37th International SAMPE Technical Conference*, Seattle, WA, 2005.
2. L. Vosteen, R. Hadcock, “Composite Chronicles: A Study of the Lessons Learned in the Development, Production, and Service of Composite Structures”, *NASA CR 4620* (1994).
3. D. Armstrong et al., “Development of a Low-Cost Integrated RTM Horizontal Stabilizer That Flies on Bell Helicopter’s MAPL”, *SAMPE Journal*, 42(3) 54-62 (2006).
4. K. Potter, “Resin Transfer Molding”, *Chapman and Hall* (1997).
5. C. Demaria, E. Ruiz and F. Trochu (2004), In-plane Anisotropic Permeability Characterization of Deformed Fabrics by Unidirectional Injections. Part 1: Experimental Results. Part 2: Prediction and Numerical Simulations, *Polymer Composites*.
6. QUIK-FORM software, ESI-Group, <http://www.esi-group.com>.
7. A. Hammami, R. Gauvin, and al. (1998). Modeling the Edge Effect in Liquid Composites Molding, *Composites - Part A: Applied Science and Manufacturing* 29(5-6): 603-609.
8. PAM-RTM software, ESI-Group, <http://www.esi-group.com>.